

# Installation Guide

## CoolMaster EDGE



# Table of content

## General

<a href="#">Table of content</a>	2
<a href="#">Safety Precautions</a>	3
<a href="#">Caution</a>	4
<a href="#">Caution</a>	5
<a href="#">What's in the box</a>	6
<a href="#">CoolMater EDGE Mounting</a>	7
<a href="#">CoolMater EDGE Layout and connectivity</a>	8
<a href="#">CoolMater EDGE Power Supply</a>	9
<a href="#">CoolMaster EDGE - Local &amp; Cloud Apps</a>	10
<a href="#">CoolMaster EDGE – GPIO Connection</a>	11

## VRF Brand Specific

<a href="#">Daikin VRV 3,4,5 – Outdoor Connection</a>	12
<a href="#">Daikin VRV 6 – Outdoor Connection</a>	13
<a href="#">Daikin VRV - Indoor Connection</a>	14
<a href="#">Daikin Non VRV - Indoor Connection</a>	15
<a href="#">Mitsubishi Electric VRF – Outdoor Connection</a>	16
<a href="#">Mitsubishi Electric VRF – Indoor Connection</a>	17
<a href="#">Mitsubishi Electric Non VRF – Indoor Connection</a>	18
<a href="#">Fujitsu VRF– Outdoor Connection</a>	19
<a href="#">Midea VRF – Outdoor Connection</a>	20
<a href="#">Toshiba VRF – Outdoor Connection</a>	21
<a href="#">Toshiba VRF– Service Adapter Connection</a>	22
<a href="#">Toshiba VRF – Indoor Connection</a>	23
<a href="#">GREE VRF GMV5/6– Outdoor Connection</a>	24
<a href="#">Samsung VRF – Outdoor Connection</a>	25
<a href="#">BACnet MS/TP</a>	26
<a href="#">BACnet IP</a>	27

Read these Safety Precautions carefully to ensure correct installation.  
This manual classifies precautions into WARNING and CAUTION



Failure to follow **WARNINGS** may result in serious injury or death

## WARNING

- Only qualified personnel can carry out the installation work.
- Ask your dealer or technical representative to install the device.
- Installation deficiencies caused by the user may lead to electric shock or fire.
- All electrical work must be performed by a licensed technician, according to local regulations and in accordance with the instructions in the installation manual.
- **Any lack of electric circuit or any deficiency caused by installation may result in an electric shock or fire.**
- Do not relocate or reinstall the CoolMaster EDGE device by yourself. Call a certified installer.
- Any deficiency caused by self re-installation of the device may result in an electric shock or fire.
- Make sure that all wiring is secured, that specified wires are used and that no external forces act on terminal connections or wires. Improper wiring connections or installation may produce heat and result in fire.
- Before touching electrical parts, turn off the unit.
- To dispose of this product, consult your dealer.



Failure to follow CAUTION may result in serious injury or property damage, and in certain circumstances, may lead to severe consequences .

## CAUTION

- Do not allow children to play with the **CoolMaster Edge device** and supervise them not to get access to the appliance.
- CoolMaster Edge device is not to be used by persons with limited physical, sensory or mental capabilities, or lack of experience and knowledge.
- Do not disassemble, modify or repair the **CoolMaster Edge device**.
- Any deficiency caused by your modification or repair may result in an electric shock or fire.
- Assure the CoolMaster Edge device never get wet.
- Water can cause damage to the CoolMaster Edge device, and may cause an electric shock or fire.
- Do not use flammable materials (e.g. hairspray or insecticide) near the CoolMaster Edge device.
- Do not clean the CoolMaster Edge device with organic solvents such as paint thinner. The use of organic solvents may cause cracking, damaging the CoolMaster Edge device, causing electrical shock or fire.
- Do not apply direct 110V AC or 220V AC to the **CoolMaster Edge device**. The maximum voltage that can be applied to the unit directly is 24V DC.
- A damaged **CoolMaster Edge** device can generate heat and cause a fire. Do not use a damaged device.



Failure to follow CAUTION may result in serious injury or property damage, and in certain circumstances, may to **severe** consequence.

### DO NOT INSTALL THE COOLMASTER EDGE DEVICE IN THE FOLLOWING LOCATIONS

- a) Where a mineral oil mist or oil spray or vapor is produced, for example, in a kitchen. Plastic parts may deteriorate and fall off or result in water leakage.
- b) Where corrosive gas, such as sulfurous acid gas, is produced.
- c) Near machinery emitting electromagnetic waves. Electromagnetic waves may disturb the operation of the **CoolMaster Edge** device and cause the unit to malfunction.
- d) Where flammable gas may leak, where there is carbon fiber or ignitable dust suspensions in the air, or where volatile flammable such as thinner or gasoline are handle Operating the **CoolMaster Edge** device in such conditions can cause a fire.
- e) High temperature area or directly flamed point. Heating and/or fire can occur.
- f) Moist area, where there is exposure to water. If water enters the inside of the **CoolMaster Edge** device, it may cause electric shock and electrical components may fail.

# What's in the box



CoolMaster EDGE

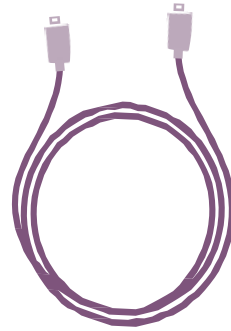

USB-C to USB-C cable



Ethernet Cable



Power Supply



USB-C to USB-A Adapter

# CoolMaster EDGE - Dimensions and mounting

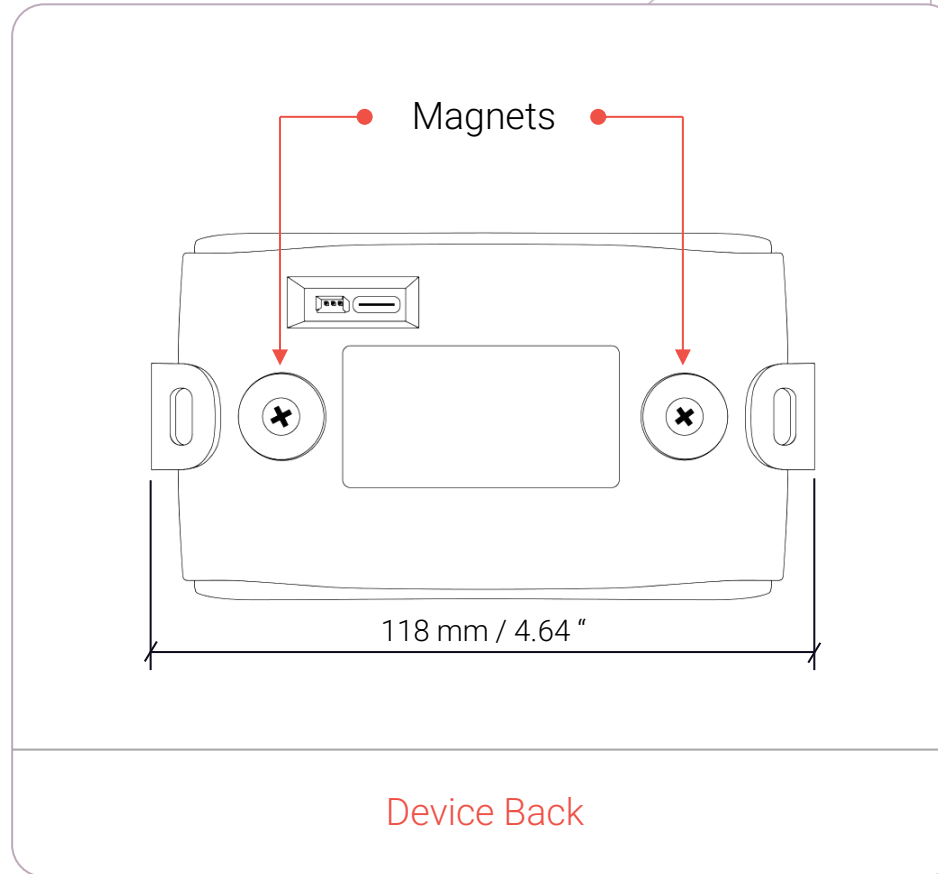
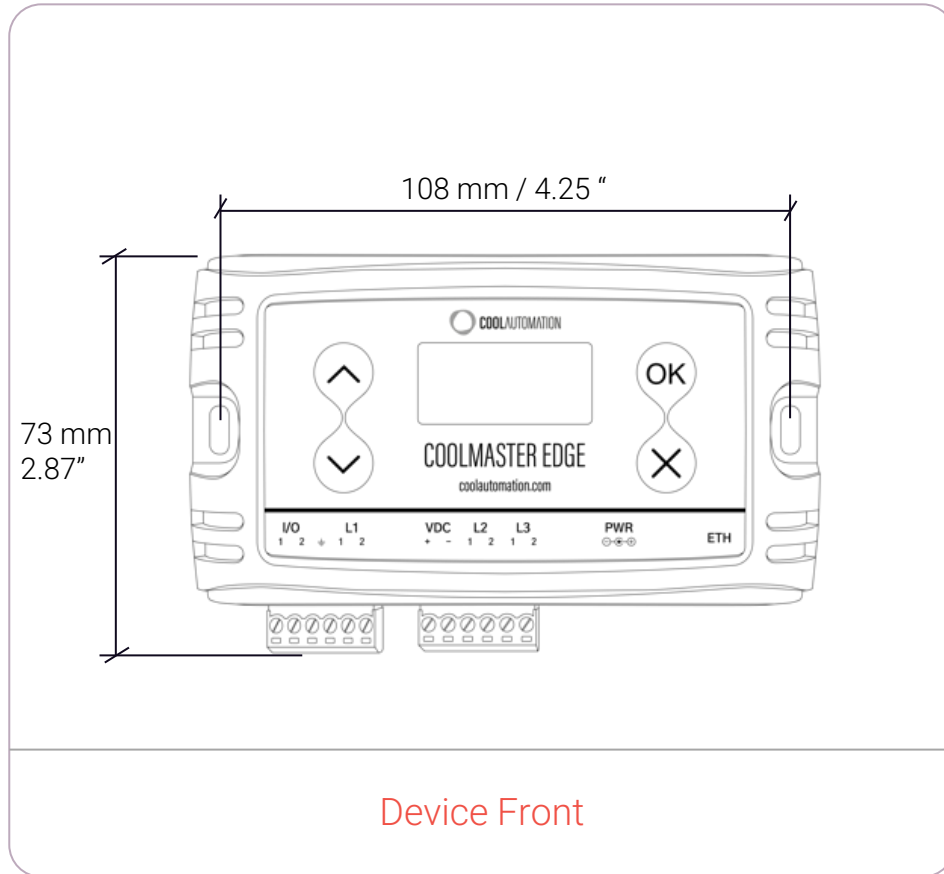

Recommended to leave 3 cm clearance below the device to allow pulling ethernet cable out

# CoolMaster EDGE - Layout and connectivity



Device Back

1. Ethernet Port
2. Power Socket – 12 VDC
3. L2, L3 & External Power connector
4. L1 & I/O Connector
5. USB-A
6. Micro SD slot
7. LCD Screen
8. Buttons
9. USB Type-C
10. Scan to register device

# CoolMaster EDGE - Power Supply Connection



Caution – Never connect both options together

Option A



Option B



# CoolMaster EDGE - Local & Cloud Apps

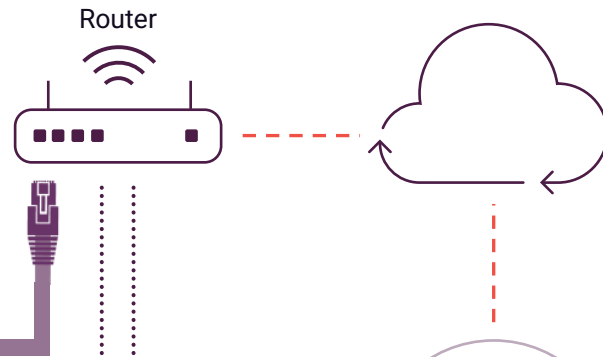

**Local Control APP**  
<http://<EDGE device IP>/ control>

**Local Setup Interface**  
<http://<EDGE device IP>/ config>



**Local Tool Box**

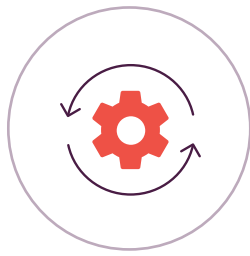

Setup Utility

**Cloud Professional APP**

<https://professional.coolremote.net>

**Cloud Control APP**

<https://control.coolremote.net>



App Store



Google Play

# CoolMaster EDGE - GPIO Connection



Caution – Use Dry Contacts Only

# Daikin VRV 3,4,5 – Outdoor line connection

- Supported device line number: L2
- No line polarity required
- Cable type – Follow Daikin installation instructions
- Set line type in the EDGE device to: **DK**
- Follow Daikin instruction on how to address the units
- Each Indoor must be set with **group** address for control
- Each system and Indoor must be set with **Airnet** address if service is required

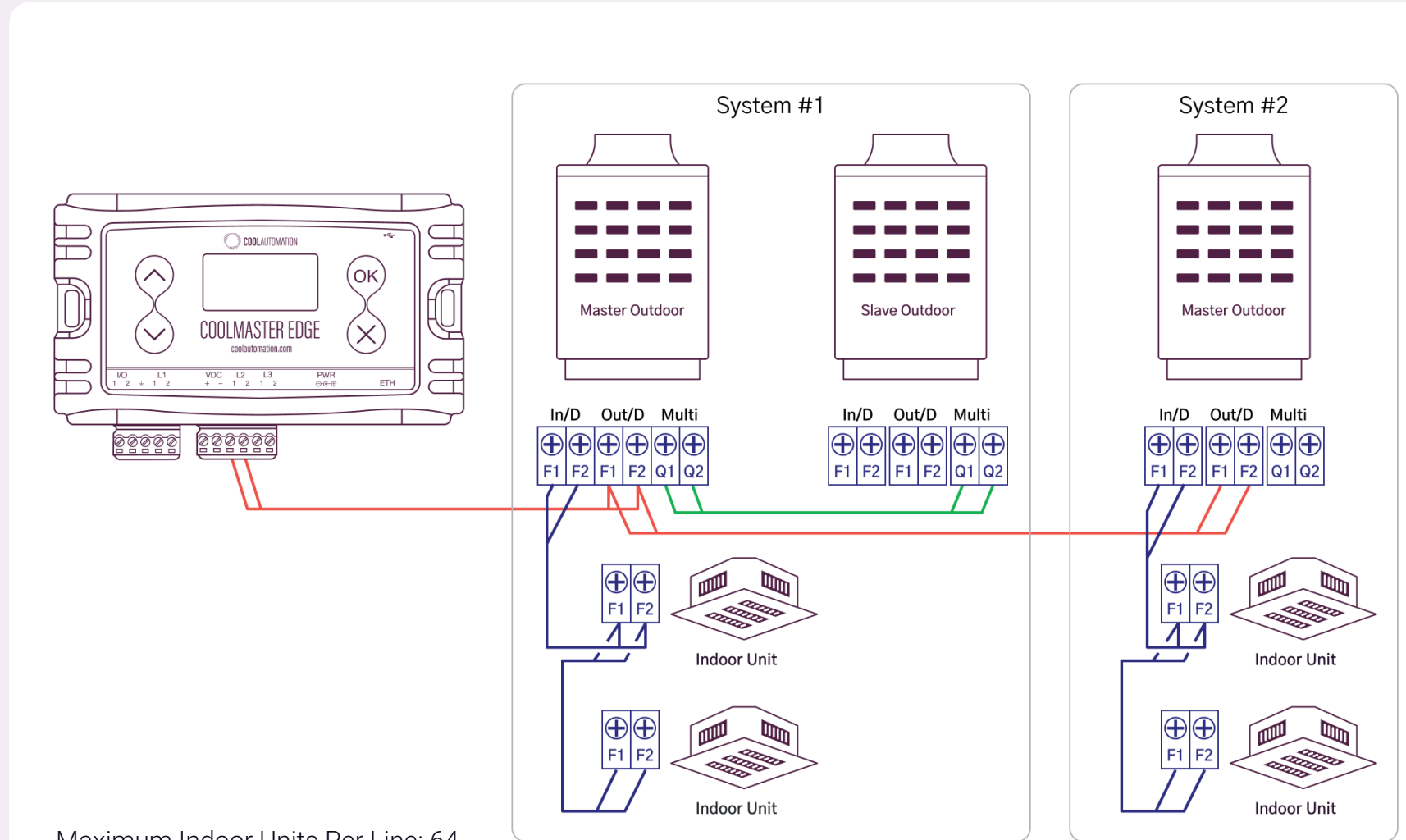

Maximum Indoor Units Per Line: 64  
Maximum Systems Per Line: 10

# Daikin VRV 6 – Outdoor line connection

- Supported device line number: L2
- No line polarity required
- Cable type – Follow Daikin installation instructions
- Set line type in the EDGE device to: **DK**
- Follow Daikin instruction on how to address the units
- Each Indoor must be set with **group** address for control
- Each system and Indoor must be set with **Airnet** address if service is required

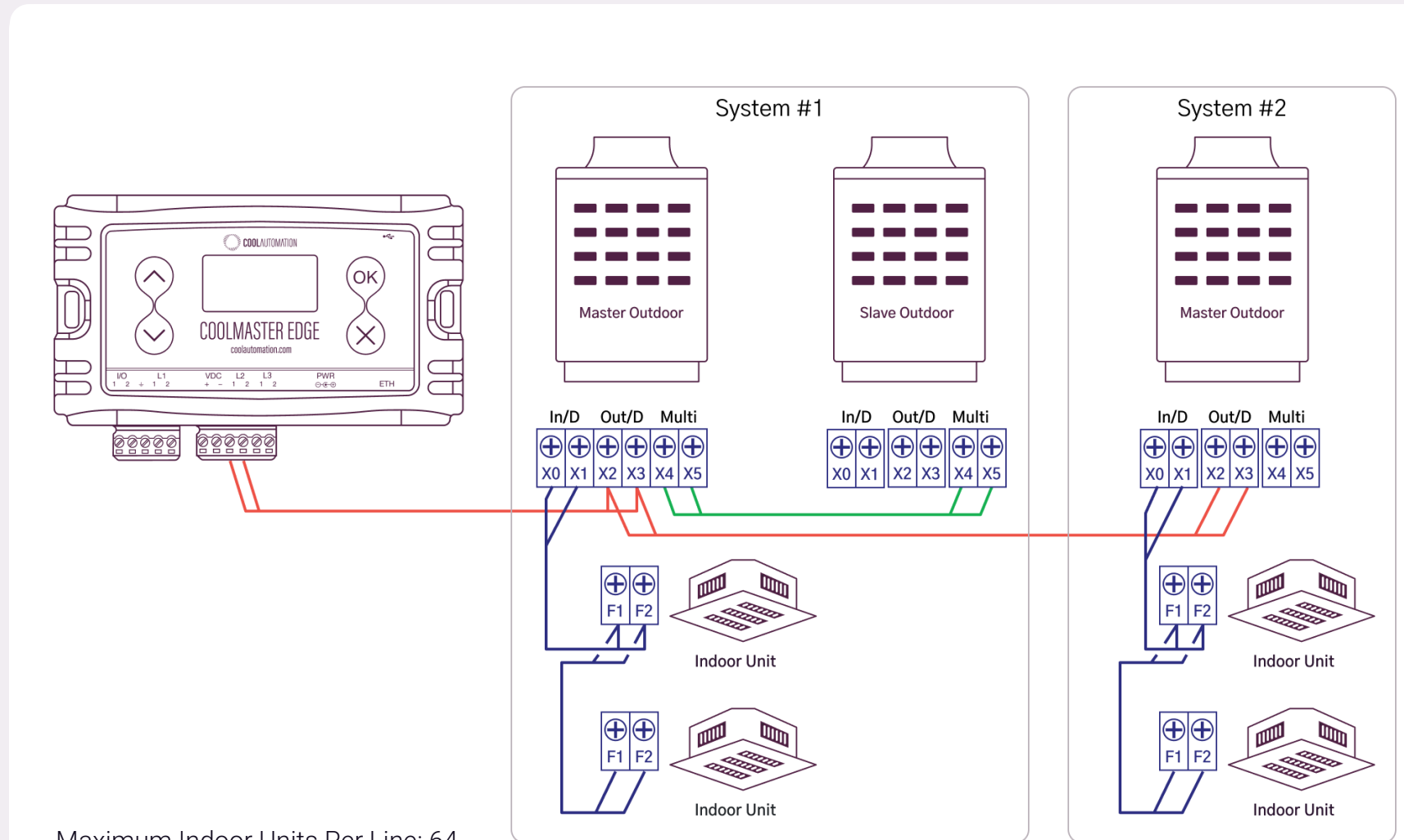

Maximum Indoor Units Per Line: 64  
Maximum Systems Per Line: 10

# Daikin VRV – Indoor line connection

- Supported device line number: L2
- No line polarity required
- Cable type – Follow Daikin installation instructions
- Set line type in the EDGE device to: **DK**
- Follow Daikin instruction on how to address the units
- Each Indoor must be set with **group** address for control
- Each system and Indoor must be set with **Airnet** address if service is required

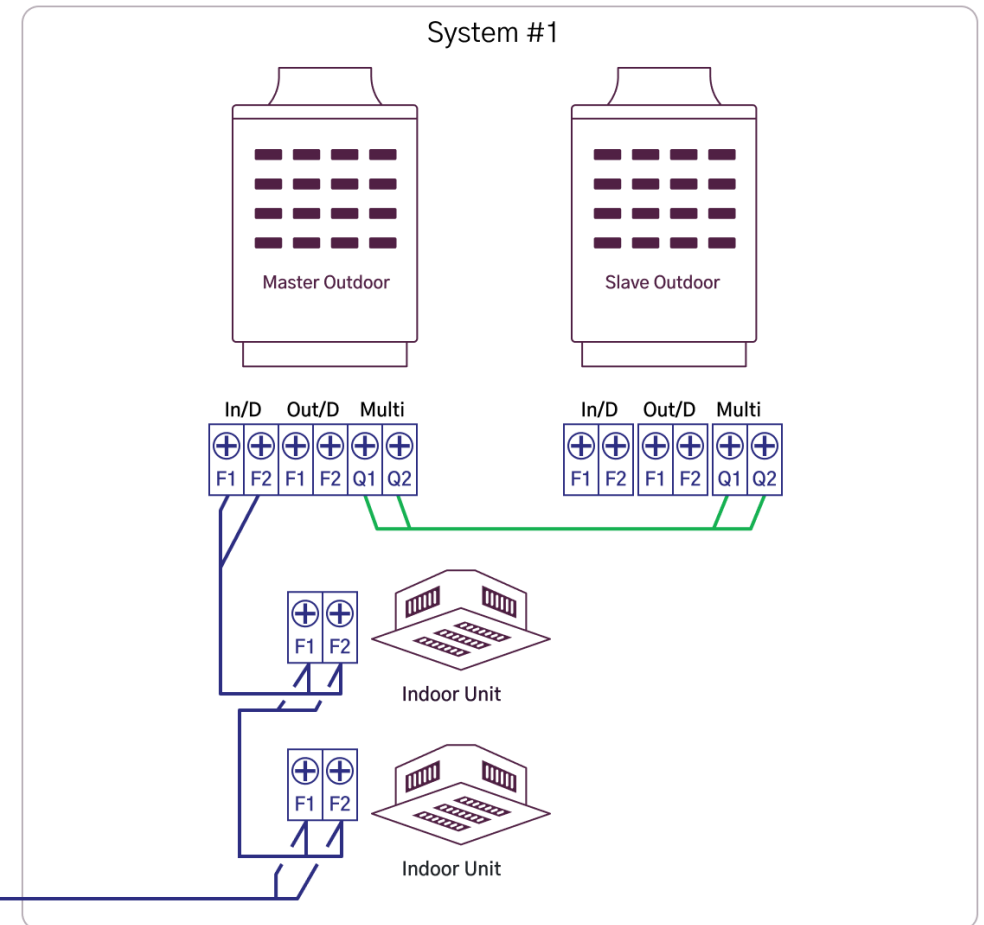
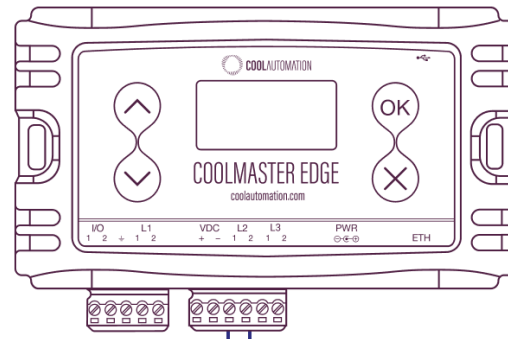

Maximum Indoor Units Per Line: 64

Maximum Systems Per Line: 1

# Daikin Non VRV – Indoor connection

- Supported device line number: L2
- No line polarity required
- Cable type – Follow Daikin installation instructions
- Set line type in the EDGE device to: **DK**
- In Case the line is not mixed with VRV units , set the Edge line DC power on,  
**Caution – Apply power from the CoolMaster Edge only if the line is free of power**
- Follow Daikin instructions on how to set up adapters address
- Each Indoor adapter must be set with unique address for control

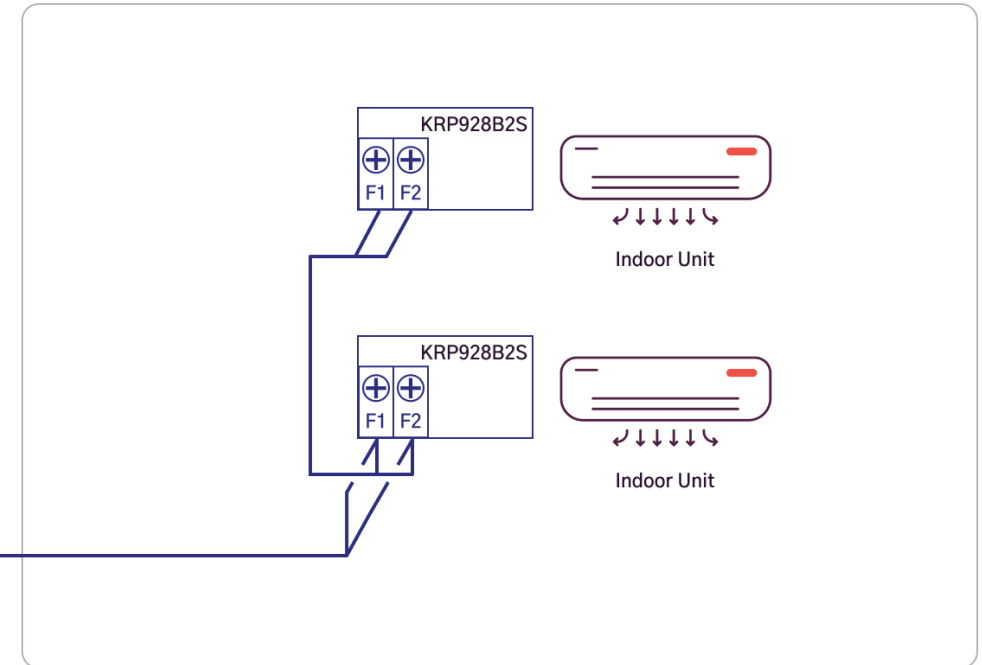
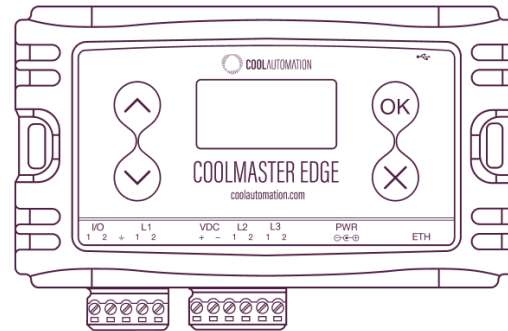

# Mitsubishi Electric VRF – Outdoor line connection

- Supported device line number: L2
- No line polarity required
- Cable type – Follow ME installation instructions
- Set line type in the EDGE device to: **ME**
- Each Outdoor and Indoor must be set with unique address
- Follow ME instruction on how to address the units
- To provide 30VDC voltage to the TB7 line move the jumper from CN41 to CN40 in only one of the outdoor units

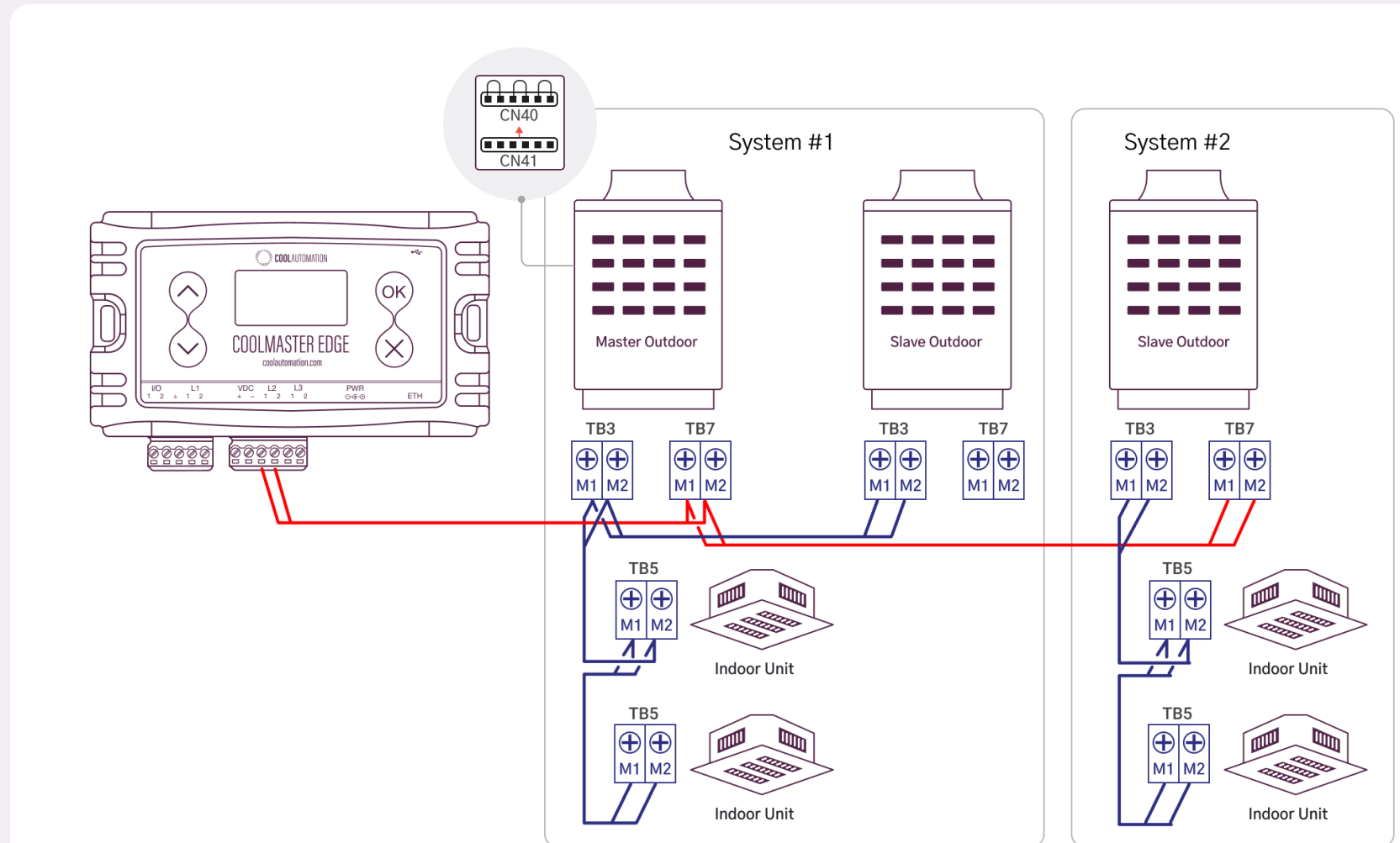

Maximum Indoor Units Per Line: 50  
Maximum Systems Per Line: 10

# Mitsubishi Electric VRF – Indoor line connection

- Supported device line number: L2
- No line polarity required
- Cable type – Follow ME installation instructions
- Set line type in the EDGE device to: **ME**
- Each Outdoor and Indoor must be set with **unique** address
- Follow ME instruction on how to address the units

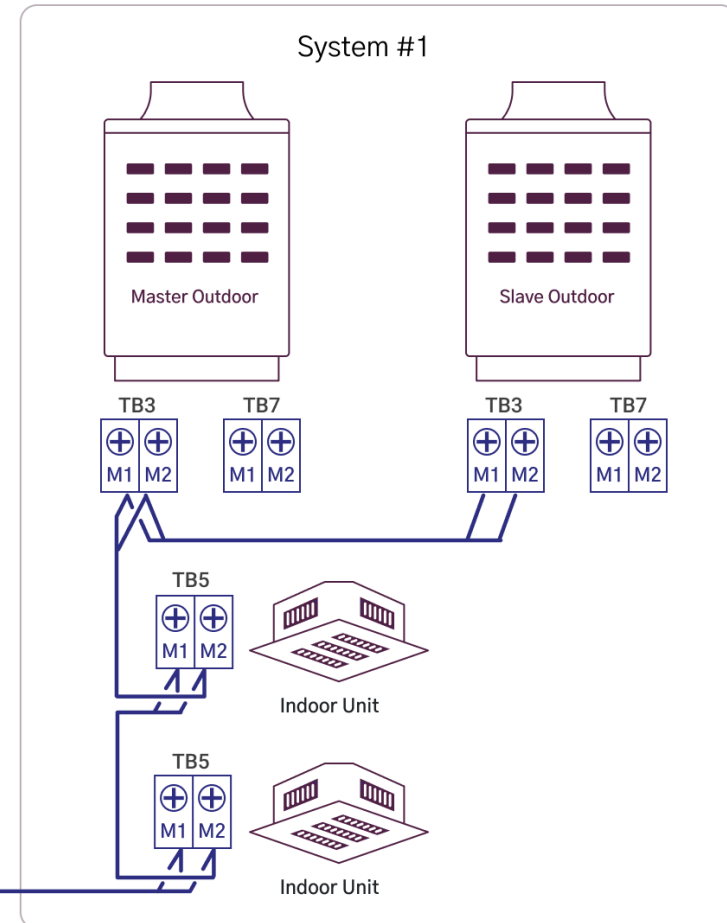
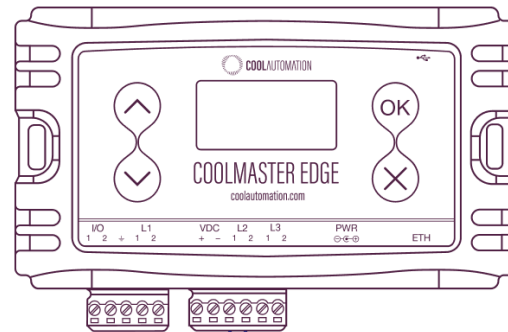

Allowed when only one system exists. | Maximum Indoor Units Per Line: 50

# Mitsubishi Electric Non VRF – Indoor connection

- Supported device line number: L2
- No line polarity required
- Cable type – Follow ME installation instructions
- Set line type in the EDGE device to: **ME**
- In Case the line is not mixed with VRF units , set the Edge line DC power on,  
**Caution – Apply power from the CoolMaster Edge only if the line is free of power**
- Follow ME instructions on how to set up adapters address
- Each Indoor adapter must be set with unique address for control

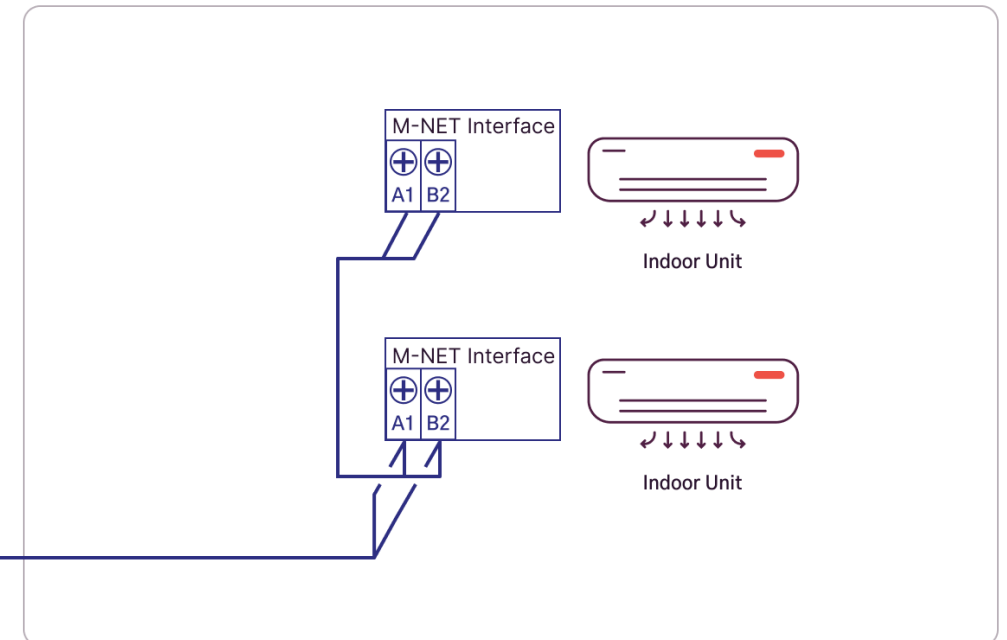
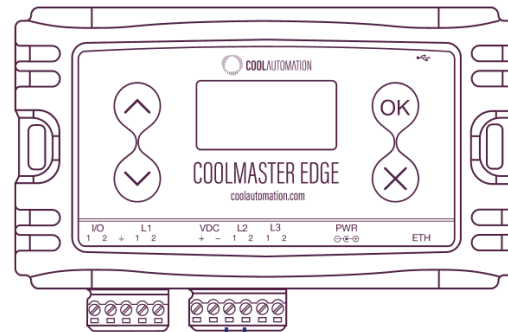

# Fujitsu VRF – Outdoor line connection

- Supported device line number: L8 (Type A USB)
- No line polarity required
- Echelon adapter U10 or U60 should be purchased from Fujitsu
- Cable type – Follow Fujitsu installation instructions
- Set line type in the EDGE device to: **FJ**
- Follow Fujitsu instruction on how to address the units
- Each system and Indoor must be set with unique address

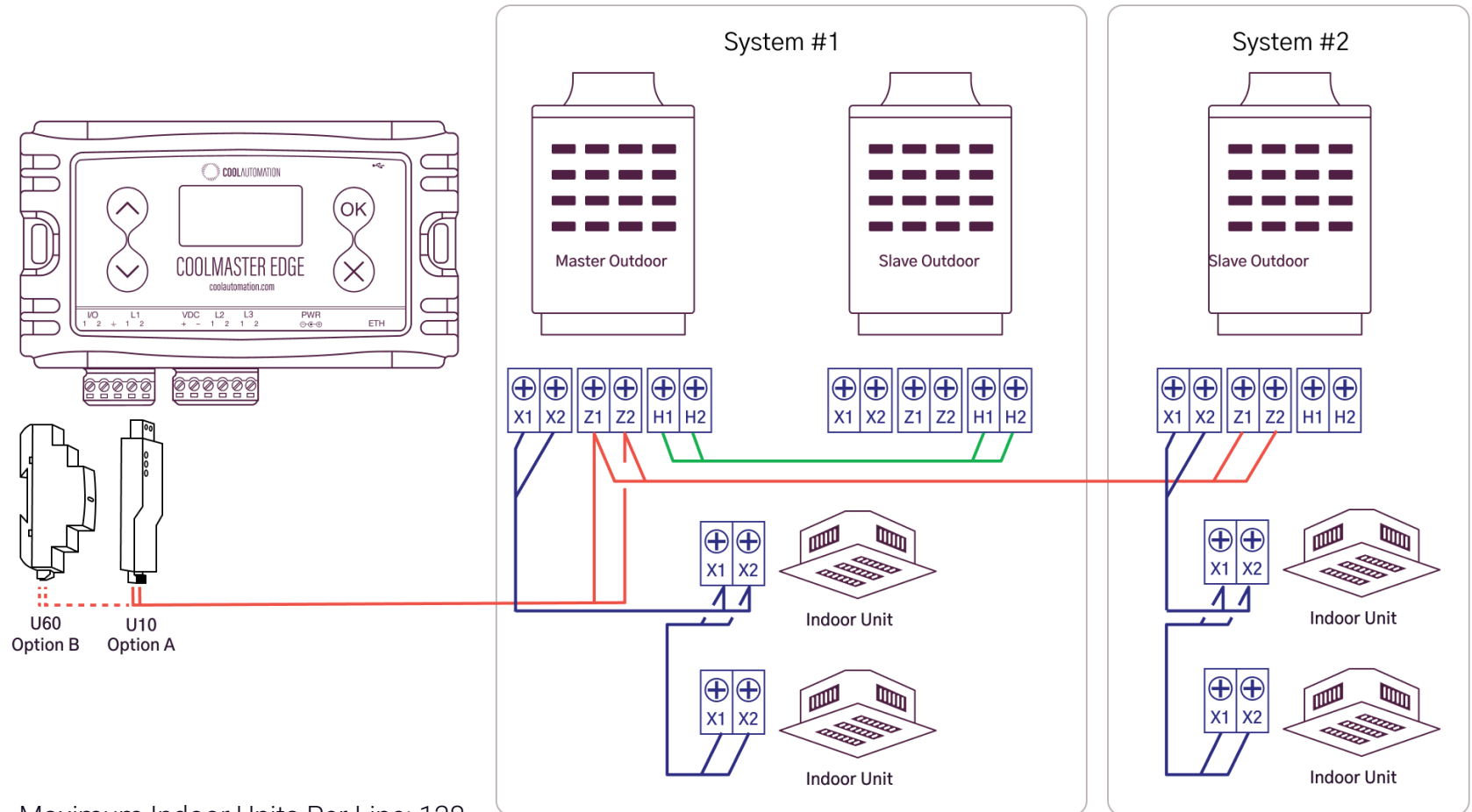

Maximum Indoor Units Per Line: 128

Maximum Systems Per Line: 16

# Midea VRF – Outdoor line connection

- Supported device line number: L1 , L2 , L3
- Line polarity is required
- Cable type – Follow Midea installation instructions
- Set line type in the EDGE device to: **MD**
- Follow Midea instruction on how to address the units
- Each system and Indoor must be set with unique address

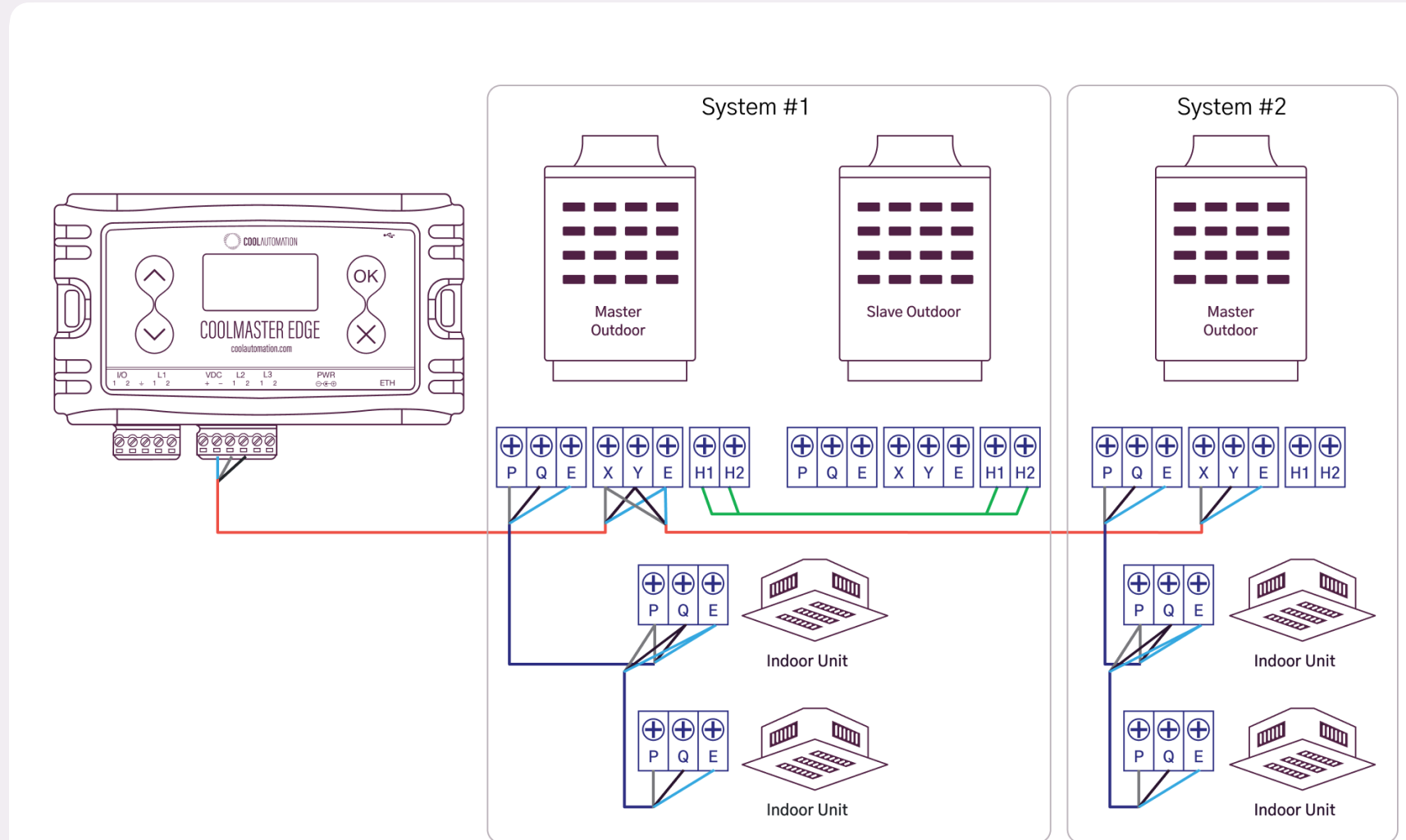

Maximum Indoor Units Per Line: 64  
Maximum Systems Per Line: 8

# Toshiba VRF – Outdoor line connection

- Supported device line number: L2
- No line polarity required
- Cable type – Follow Toshiba installation instructions
- Set line type in the EDGE device to: **TO**
- Each Outdoor and Indoor must be set with unique address
- Follow Toshiba instruction on how to address the units

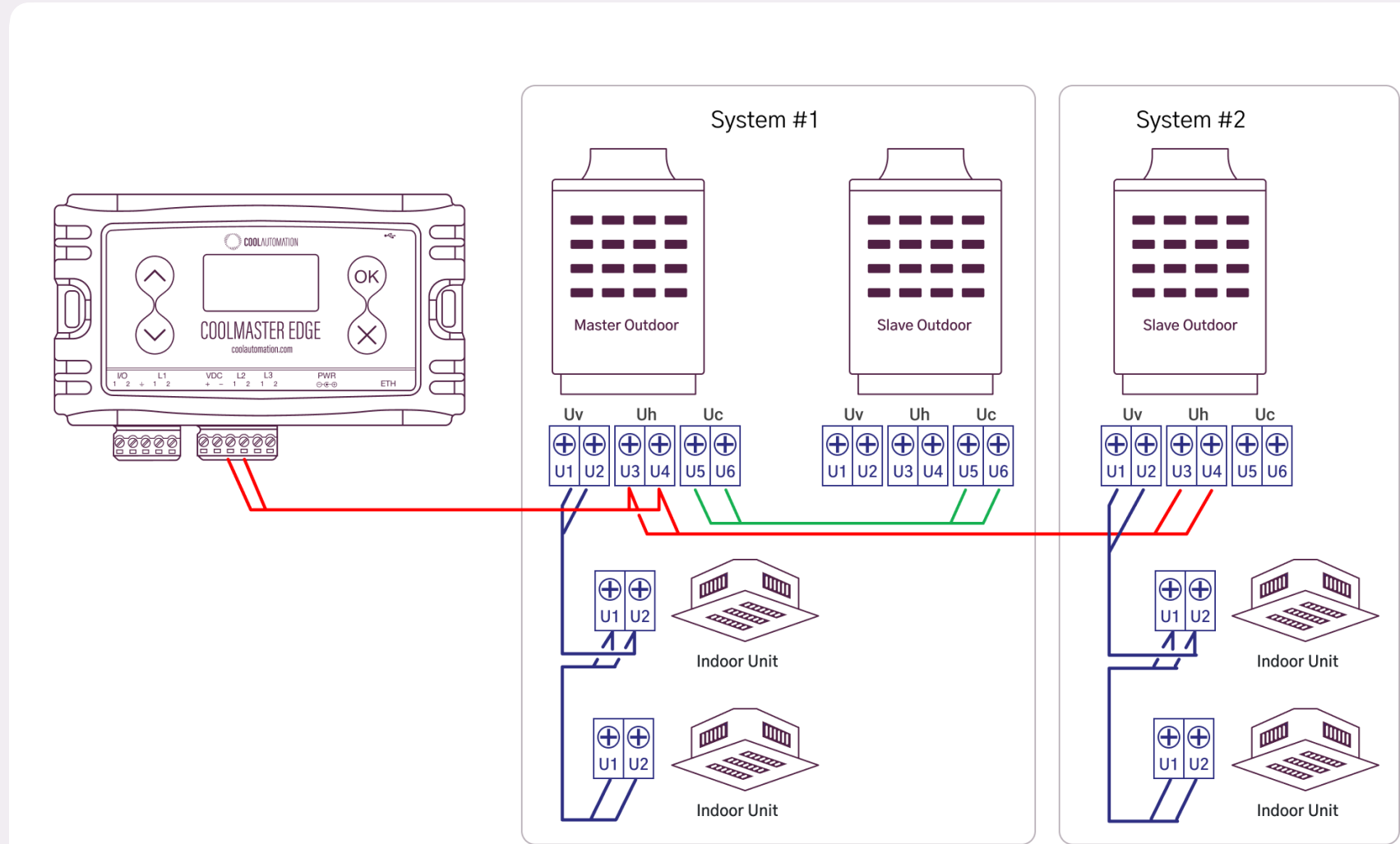

Maximum Indoor Units Per Line: 64  
Maximum Systems Per Line: 15

# Toshiba VRF – Service Adapter connection

- Not Compatible with SMMS-U
- Adapters should be installed on the master outdoor of each system
- Each adapter should be set with a unique address using the dip switches as shown in the drawing
- Maximum service adapters per line is limited to 8
- It is best practice but not a must to set the adapter address the same as the system address it is connected to
- GPIO terminals on the adapter are not in use

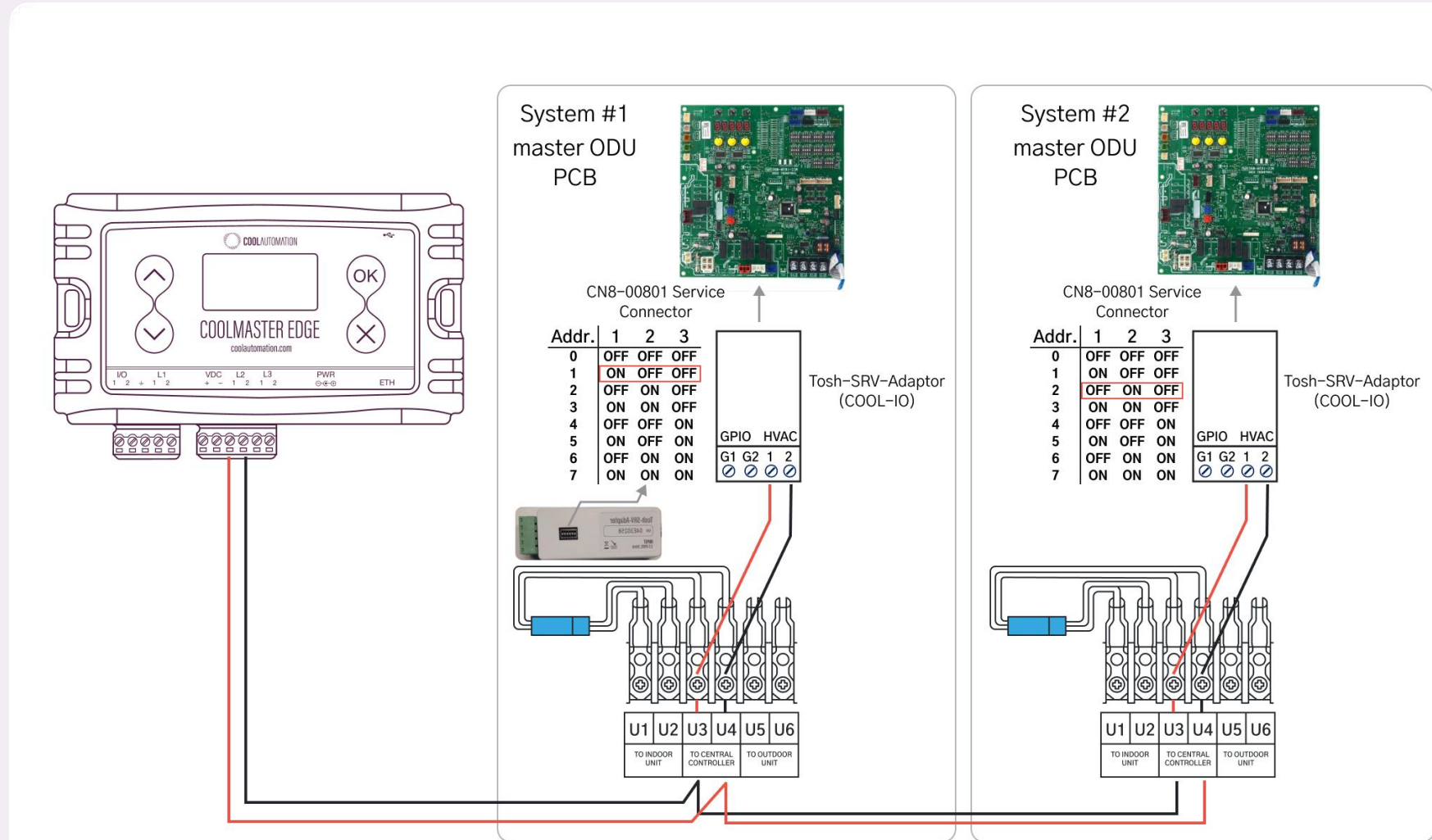

# Toshiba VRF – Indoor Line Connection

- Supported device line number : L2
- No line polarity required
- Cable type – Follow Toshiba installation instructions
- Set line type in the EDGE device to: **TO**
- Each Outdoor and Indoor must be set with unique address
- Follow Toshiba instruction on how to address the units

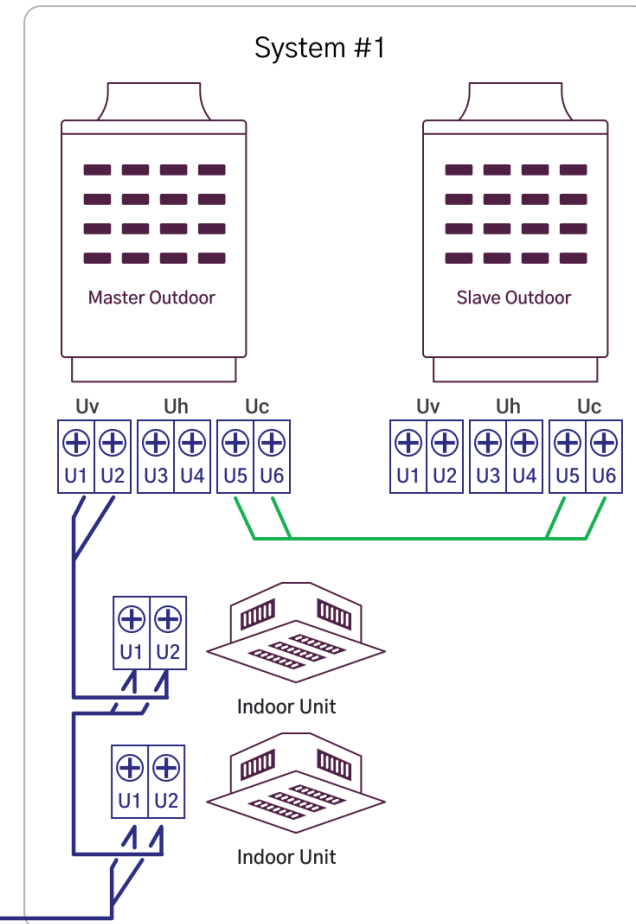
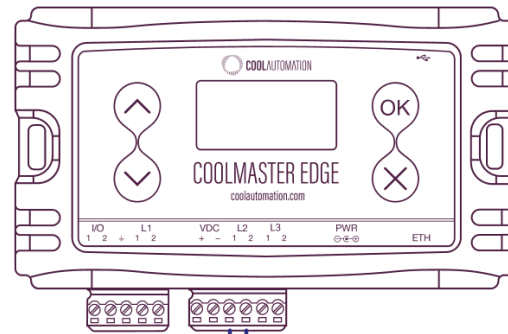

Maximum Indoor Units Per Line: 64  
Maximum Systems Per Line: 1

# GREE GMV5/6 VRF – Outdoor line connection

- Supported device line number: L2
- Line polarity is required
- Cable type – Follow GREE installation instructions
- Set line type in the EDGE device to: **GMV5**
- Follow GREE instruction on how to address the units
- Each system and Indoor must be set with unique address

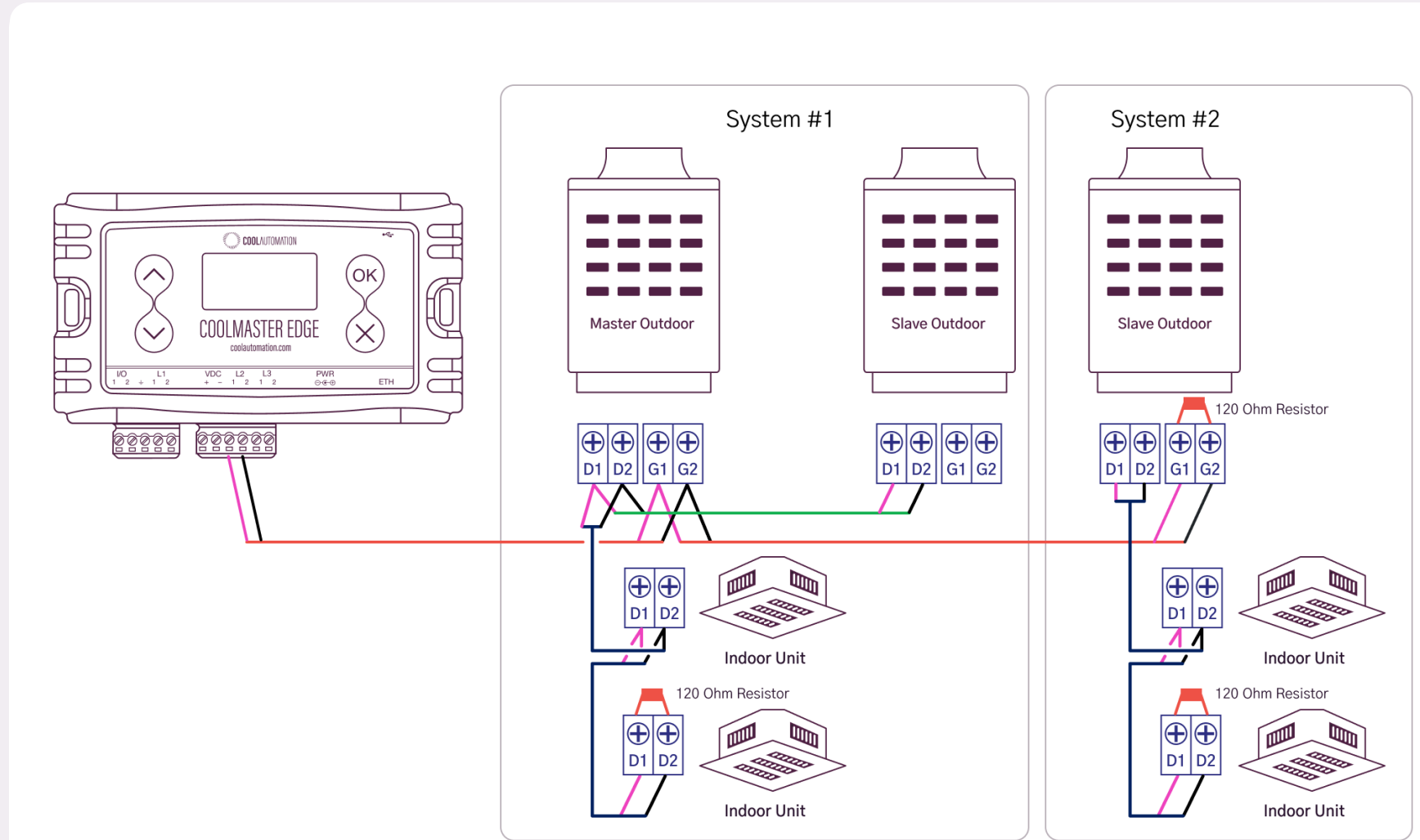

Maximum Indoor Units Per Line: 64  
Maximum Systems Per Line: 15

# Samsung VRF – Outdoor line connection

- Supported device line number: L1 , L2 , L3
- Line polarity is required
- Cable type – Follow Samsung installation instructions
- Set line type in the EDGE device to: **SM**
- Follow Samsung instruction on how to address the units
- Each system and Indoor must be set with unique address

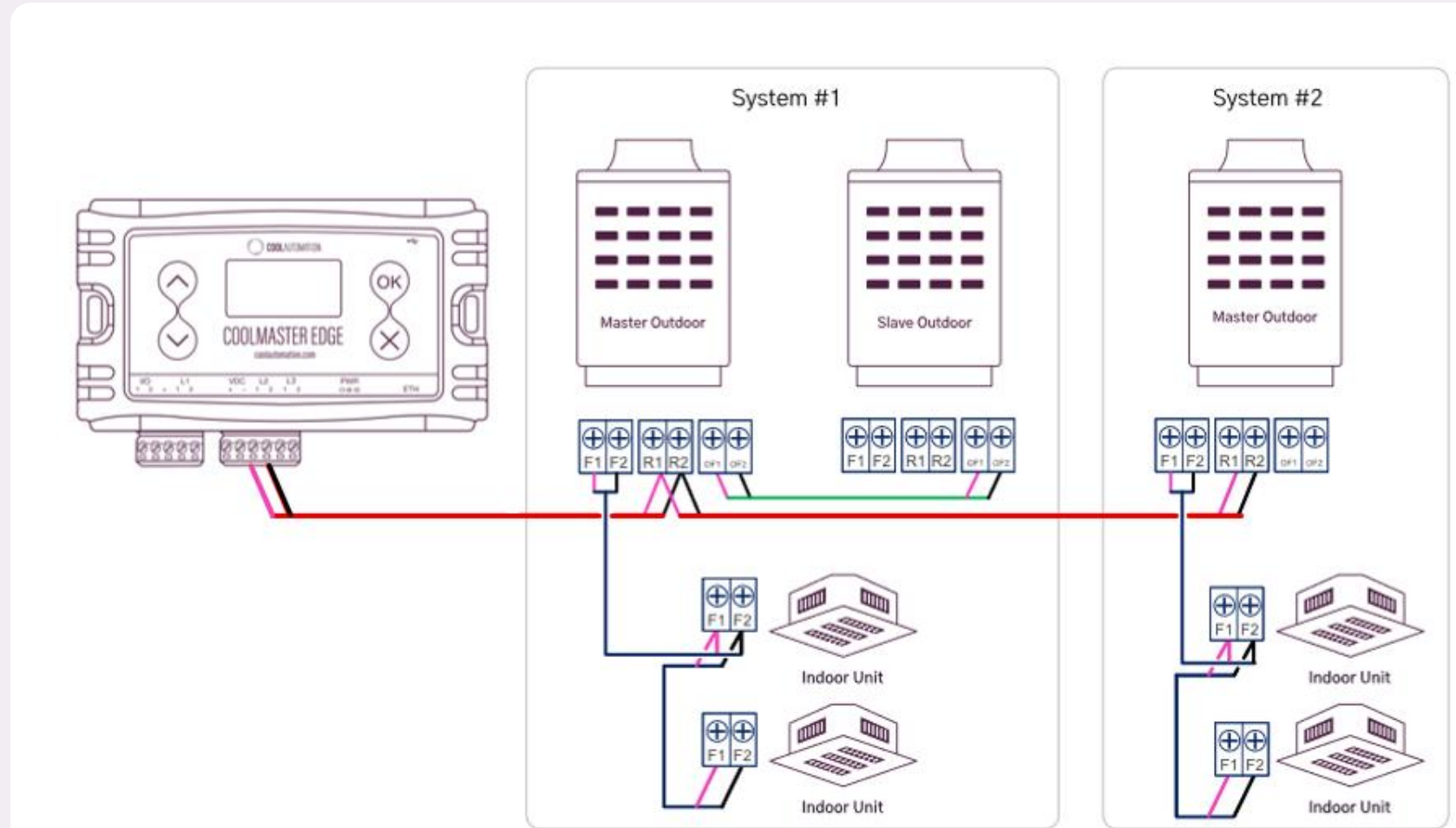

Maximum Indoor Units Per Line: 64  
Maximum Systems Per Line: 16

# BACnet MS/TP Controller integration

- Supported device line number: L1 , L2 , L3
- Line polarity is required
- Cable type – 22 AWG shielded twisted pair
- Set line type in the EDGE device LINES menu to: **BACnet MS/TP**
- Assign each device with a unique MAC address, refer to the controller manufacturer’s user’s manual on how to set the MAC address.
- Assign the EDGE device with an ID (BACnet Instance)
- If network termination is required, install the provided 120 ohm resistor across Edge terminals 1,2 of the desired line (L1, L3) or enable via software for L2. Install a corresponding resistor on the other end of the MS/TP network
- Supported line baud rates are 9600 and 38400

The screenshot shows the configuration page for the COOLMASTER EDGE device. The 'LINES' menu is selected, and the 'Type' is set to 'BACnet MS/TP'. The 'Termination 120 Ohm' is set to 'off', 'Scan' is 'off', and the 'Baud rate' is '38400'. The 'Polarity' is set to 'Normal (A/B)'. The 'Vendor ID' is '1164', the 'Model name' is 'CoolMasterEdge', and the 'Device ID' is '42'.

Maximum Controllers Per Line: 64

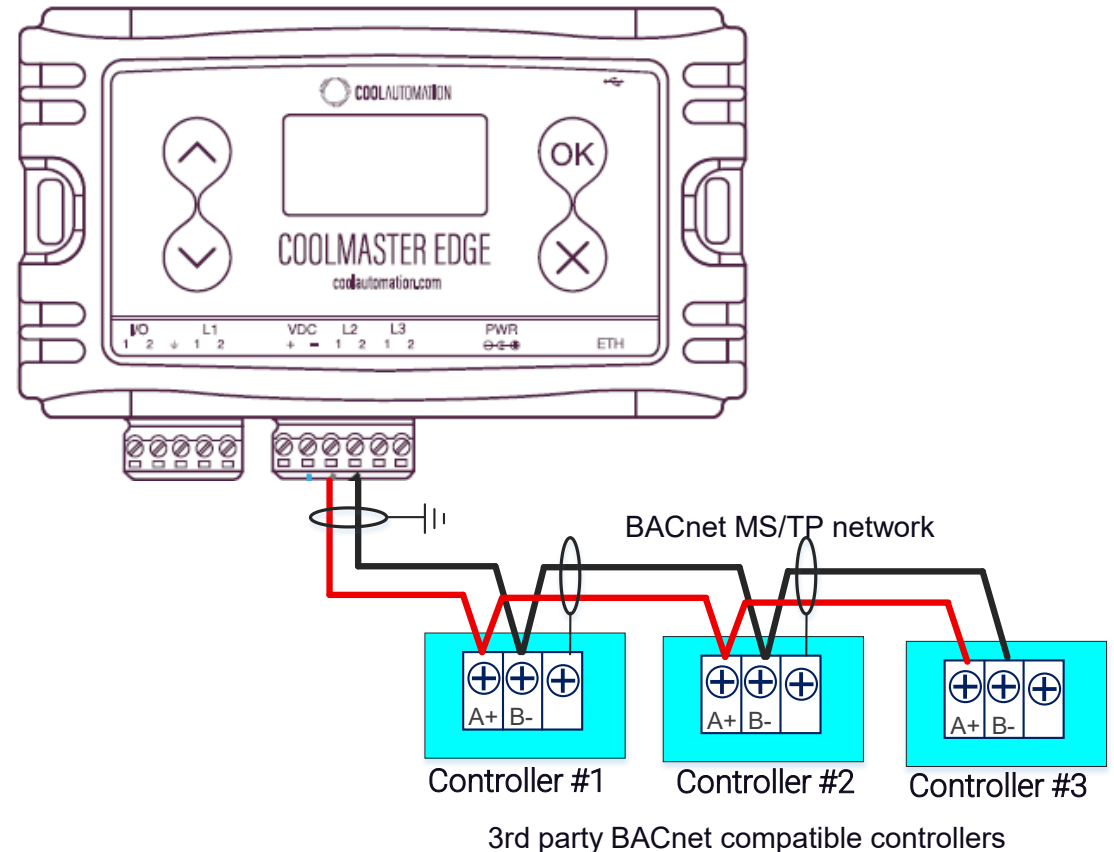

# CoolMaster EDGE – BACnet IP Integration

- **Enable** BACnet/IP in the EDGE device in the BACNET/IP menu
- Assign the EDGE device with an ID (BACnet instance)
- Ensure that all device IP addresses are located on the same subnet (i.e. 192.168.1.xxx)

Interfaces

enabled

Name \*  
ip

Type \*  
IP

Vendor ID \*  
1164

Device ID \*  
94

Device Network (1-65534) \*  
1

Model name \*  
CoolMaster EDGE

BIP port  
47808

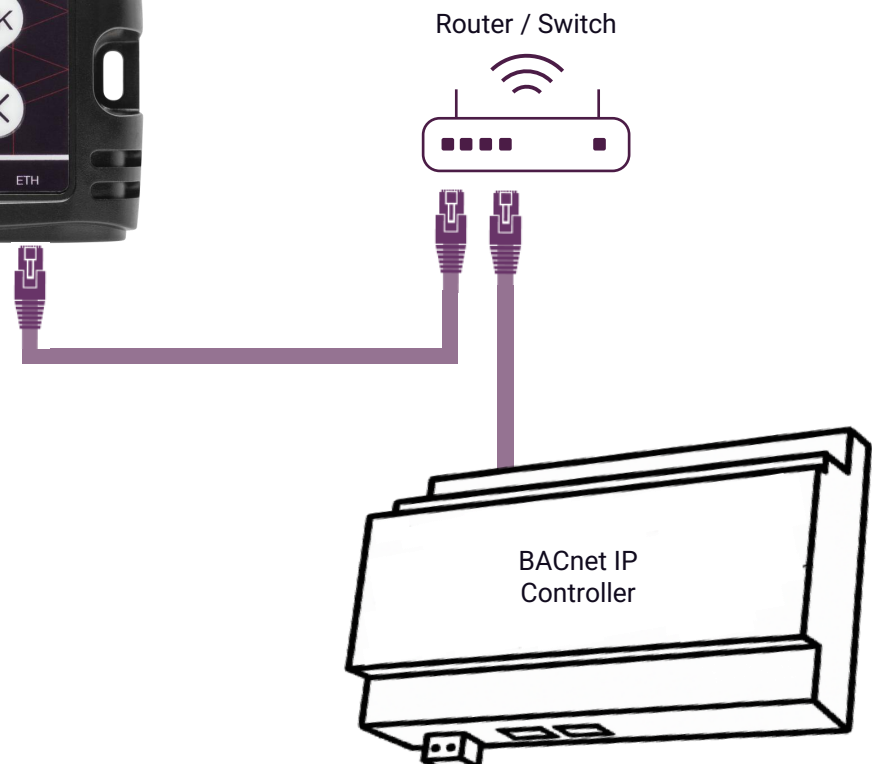

# Need more help?

Visit us at <https://support.coolautomation.com/>

Follow us:

